

## Paranco in versione con carrello meccanico a catena CTM

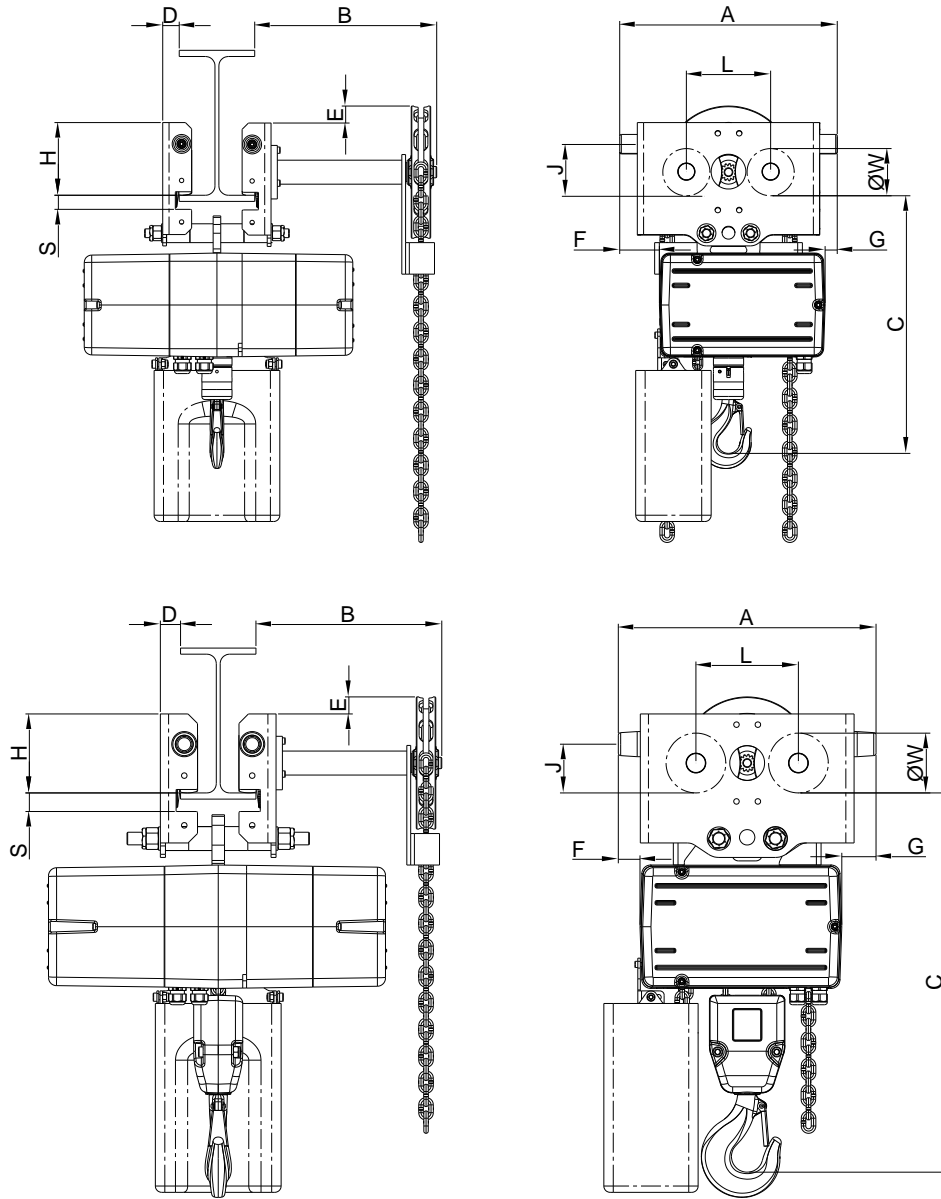

Grandezza paranco	Tiri catena	Carrelli o tipo	Dimensioni di ingombro (mm)											Ala trave carrello (mm)			Peso (kg)
			A	B	C	D	E	F	G	H	L	J	ØW	min	max	S max	
P100	1	CTM2	346	290	410	26	30	63	19	116	134	70	75	82	220	14	51
P200	1	CTM2	346	290	490	26	30	37	12	116	134	80	75	82		14	76
P300	1	CTM2	346	290	490	26	30	37	12	116	134	80	75	82		14	95
	2	CTM3	410	300	605	32	30	35	55	125	163	77	95	100		28	112